

**AM 345 PUMP DRIVE**

MAXIMUM INPUT POWER 430 KW (577 HP)  
FOR RATIO 1.00:1 @ 2600 RPM

**QUALITY IS STANDARD:**

- CAST IRON HOUSING
- CASE HARDENED AND GROUND SPUR GEARS
- BALL BEARINGS
- CASE HARDENED SHAFTS
- VITON SEALS ON INPUT SHAFT
- OUTPUT ROTATION OPPOSITE THE DIRECTION OF INPUT ROTATION
- GEAR RATIOS IDENTICAL ON ALL OUTPUTS
- MODULAR DESIGN

**AM 345 TECHNICAL DATA**

RATIO :1	MAXIMUM INPUT TORQUE N-m (lbf-ft)	MAX. OUTPUT TORQUE PER PUMP PAD N-m (lbf-ft)	MAXIMUM INPUT SPEED RPM	MAXIMUM OUTPUT SPEED RPM	OIL QUANTITY L (gal)
0.51	2080 (1534)	530 (391)	1950	3824	5.5 (1.45)
0.58	2010 (1482)	580 (428)	2050	3534	5.0 (1.32)
0.67	1910 (1409)	640 (472)	2200	3284	4.4 (1.16)
0.76	1840 (1357)	700 (516)	2300	3026	4.0 (1.06)
0.89	1680 (1239)	750 (553)	2400	2697	3.7 (0.98)
1.00	1620 (1195)	810 (597)	2600	2600	3.6 (0.95)
1.31	1390 (1025)	910 (671)	3000	2290	3.0 (0.79)
1.48	1270 (937)	940 (693)	3200	2162	2.8 (0.74)

See reverse for selection procedures.

**AM 345 DIMENSIONS**

Basic Pump Drive  
Weight: 154 kg (339 lb)

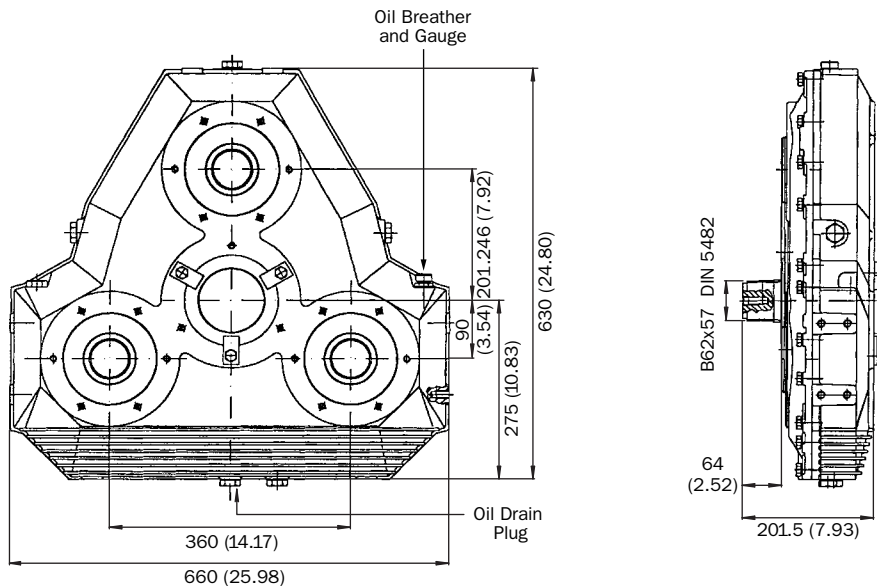

Maximum torque and maximum speed may be limited by clutch option.

Specifications subject to change without prior notice in the interest of continual product improvement.

Contact your local Twin Disc representative for engineering specifications.



With two plate 11" clutch  
**AM 345 BD 290**

With two plate 14" clutch  
**AM 345 BD 2200**

With three plate 14" clutch  
**AM 345 BD 3300**

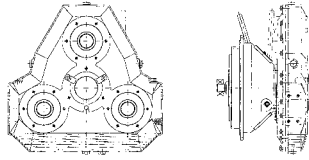

Independent Mount with two plate 11" clutch  
**AM 345 BDS 290**

Independent Mount with two plate 14" clutch  
**AM 345 BDS 2200**

Independent Mount with three plate 14" clutch  
**AM 345 BDS 3300**

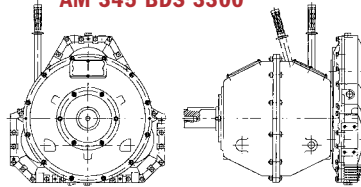
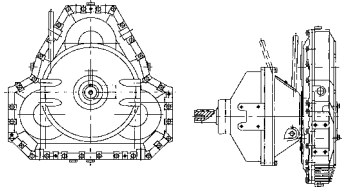

**TECHNICAL DATA FOR AVAILABLE CLUTCHES** See below for selection procedures

CLUTCH TYPE	SAE SIZE	MAXIMUM	MAXIMUM	POWER	MODEL	WEIGHT
		INPUT TORQUE N-m (lbf-ft)	SPEED RPM	kW (hp)		kg (lb)
BD 290	1, 2 or 3	880 (649)	2900	150 (201)	AM 345 BD 290	188 (414)
BD 2200	1	1960 (1446)	2400	230 (308)	AM 345 BD 2200	255 (562)
BD 3300	1	2940 (2168)	2400	320 (429)	AM 345 BD 3300	298 (657)
BDS 290	–	880 (649)	2900	150 (201)	AM 345 BDS 290	215 (474)
BDS 2200	–	1960 (1446)	2400	230 (308)	AM 345 BDS 2200	365 (805)
BDS 3300	–	2940 (2168)	2400	320 (429)	AM 345 BDS 3300	389 (858)

All clutch engagements to be with prime mover below 1000 RPM. high inertia loads may require use of larger clutch. Contact Twin Disc application engineering department for assistance.

\* Applied torque equals 80% or less of maximum input torque.

**PUMP DRIVE SELECTION PROCEDURE**

1. Identify the number and type of hydraulic pumps to be applied.
  2. Check the maximum torque absorbed by the pump or pumps on each output of the pump drive.
  3. Check the maximum power/torque entering the pump drive from the prime mover.
  4. Compare the size of the hydraulic pumps to the selected pump drive installation dimensions to determine if the proper clearance exists to mount the pumps on the pump drive.
  5. Select the desired input configuration:
    - B – Basic mount, either with drive plate or rubber block drive
    - BD – Engine mounted clutch input
    - BDS – Independently mounted clutch input
- If a BD or BDS option is selected, verify that the input speed does not exceed the maximum allowable speed for the clutch and that the applied torque does not exceed 80% of the maximum torque rating of the clutch.
6. Verify that the torque value of each output is below the maximum value shown for the chosen pump drive.
  7. Verify that the input speed does not exceed the maximum input speed shown for the pump drive.
  8. Select the proper output option for pump adaptation. SAE adapters are available for all pump drives. Other adaptations may be available, contact Twin Disc for non SAE adaptations.
  9. Identify cooling requirements:
    - Oil operating temperature must not exceed 105°C (221°F) with synthetic oil or 80°C (176°F) with mineral oil.
    - Depending on the input power, application and duty, a cooling system may be necessary.
    - It is advisable to check the oil temperature during the first few hours of work to make sure it does not exceed the maximum temperatures listed.
    - All pump drives (except AM 216 and AM 320) can be equipped with a cooling system consisting of an oil circulating pump mounted on the input shaft on the pump side, and oil/water cooler and required piping and fittings.

Twin Disc, Incorporated reminds users of these products that their safe operation depends on use in compliance with engineering information provided. Users are also reminded that safe operation depends on proper installation, operation and routine maintenance and inspection under prevailing conditions. It is the responsibility of users (and not Twin Disc, Incorporated) to provide and install guards or safety devices which may be required by recognized safety standards or by the Occupational Safety and Health Act of 1970 and its subsequent provisions.

**United States of America • Australia • Belgium • France • Italy • Singapore • Switzerland**

For nearly a century, we've been putting horsepower to work by designing, engineering and manufacturing rugged-duty industrial products. Our products and our reputation are bolted to the most renowned engine manufacturers and equipment OEMs in the world. Our mission is to make your machines and vehicles more productive, more durable, more operator-friendly, more cost-effective. From design and installation consultation through after-sale support, Twin Disc and its distributors are committed to your business. No one knows more about managing horsepower in more ways than Twin Disc.

**TRANSMISSIONS • CLUTCHES • PTOS  
 PUMP DRIVES • TORQUE CONVERTERS  
 GEARBOXES • HYDRAULIC PTO PRODUCTS**



**Twin Disc, Incorporated  
 Racine, Wisconsin 53403 USA  
 Phone +1-262-638-4000  
 Fax +1-262-638-4482  
 www.twindisc.com**

Bulletin-AM345  
 © 2012, Twin Disc, Incorporated  
 Printed in the USA - 3/2012